

FUTURE

Tomorrow starts today



SECURITY

THE MOST DISCERNING FACTOR OF ARCHITECTURE



The RPF Headquarters, Kigali, Rwanda
Architect: Symbion

Personal and
community
safety ensured
with security
glass solutions in
varying degrees
of protection

Inside



Applications 03

BULLETSHIELD

BULLETSHIELD Glass	04
BULLETSHIELD Glazing Systems	07
BULLETSHIELD Testing	08

BURGLARSHIELD

BURGLARSHIELD Glass	10
BURGLARSHIELD Glazing Systems	13
BURGLARSHIELD Testing	14



BLASTSHIELD

BLASTSHIELD Glass	16
BLASTSHIELD Glazing Systems	20
BLASTSHIELD Testing	22
Who We Are	24
Key Indicators	25

Because nothing is more precious than your life

Personal and community safety is perhaps the single most discerning factor when designing the architecture, specially in high-risk areas such as consulates, banks and institutions.

FUTURE provides the industry's most extensive range of security glass solutions with varying degrees of protection conforming to the world's leading standards.



The Need for Security



PRISONS

When the safety of officers and inmates is at stake, bulletproof glass plays a vital role in this situation. Bullet-proof windows are the standard requirements needed for protection and security within prison cell environments.



BANK TELLER COUNTERS

Bank teller counters are the most sensitive locations in a banking establishment and need to be protected against bullets and forced intrusion. Our solutions are custom-designed to suit individual counter requirements.



EMBASSIES AND CONSULATES

Embassies and consulates are unarguably a nation's most protected spaces in foreign soil with an extremely high risk of attack. Entry points, doors and security cabins thus need to be completely protected to withstand any kind of terrorist attack - be it intrusion related, blast related or bullet related and in some cases, even against fire. With several installations already, our experienced team can actively consult usage of security glass based on the location and protection level.



SECURITY CABINS

Almost all security cabins today are enclosed with glass, but that also makes the staff vulnerable to attacks if the glazing is not intrusion resistant. Ideally, all security cabin structures should be glazed with a minimum of P6B intrusion resistance to protect the security personnel. We can also offer curved glasses for this application.

FUTURE | GLASS





BULLETSHIELD

For complete safety against bullet attacks

Designed for comprehensive safety against bullet attacks, our **BULLETSHIELD** glass can be custom-designed to meet specific safety criteria and architectural glazing requirements, and can withstand various bullets and missile velocities, from rifles to handguns and Kalashnikovs. It can also be combined with ultra-clear reflective and tinted glass options to meet aesthetic design criteria. Moreover, all our glasses are also available in spall-resistant versions.

European EN 1063 BR Levels	BR2 to BR7
American UL 752 Levels	Level 1 to Level 5
Thickness Range	19mm to 70mm

BULLETSHIELD PLUS

Specially configured with highly durable polycarbonate interlayers or special films to provide spall resistance against glass shrapnel or fragments that might erupt from the inside surface due to bullet impact.

BULLETSHIELD WHITE

Incorporating low-iron ultra clear glass instead of regular clear glasses these units do away with the heavy green tint that is characteristic in thicker units, providing beautiful visibility and near total clarity.

BULLETSHIELD CURVED

All bullet-resistant configurations can also be designed using curved glasses. These units are ideal for automobile windscreens and side glasses and can also satisfy architectural demands.

Used for bank teller counters, embassies and consulates

The **BULLETSHIELD** Level

As per European Standard EN 1063

Resistance Class	Glazing (EN 1063)	Weapon/ Caliber	
FB 1	BR 1	Rifle 22 LR	
FB 2	BR 2	9 mm Parabellum	
FB 3	BR 3	.357 Magnum	
FB 4	BR 4	.357 Magnum + .44 Rem. Magnum	
FB 5	BR 5	Rifle 5.56 x 45	
FB 6	BR 6	Rifle 5.56 x 45 + Rifle 7,62 x51	
FB 7	BR 7	Rifle 7.62 x 51 (Hard Steel Core Projectile)	

Production and Quality Control

The entire series of **BULLETSHIELD** glasses is manufactured through a dedicated two-step process: first to de-air and heat the glass and interlayer combination in a vacuum chamber and second, pressurize under carefully controlled heat and pressure parameters in an autoclave. This two-step process ensures perfect sealing and bonding of glass-glass or glass-polycarbonate with the interlayers resulting in a durable, high-quality product.

The entire processing cycle is controlled by a stringent quality assurance program, which envelopes all production criteria starting with the thickness and combination analysis to the parameters and settings chosen to control the production process. Our team shall gladly assist you in selection of the right glass combination for your requirement and can also provide useful after-delivery services such as handling and installation procedures.

The **BULLETSHIELD** System

Throughout the world, all civil and military settlements are unfortunately under threat. To protect human lives and high value properties against attacks with heavy caliber weapons is no longer a luxury but a necessity.

While improving our life and property safety, it is also important to use a product that is

aesthetically designed and that does not distort the architectural texture. Our bullet-resistant façade system offers primary protection from attack by heavy caliber weapons and firearms while maintaining its aesthetic look. Bullet resistant systems are tested to provide the ultimate protection against different levels of threat.

System Offerings

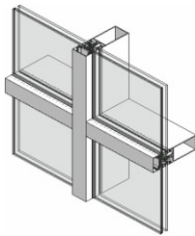

Curtain Walls

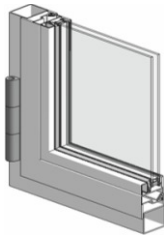

Doors

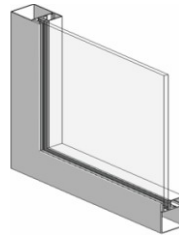

Fixed Windows

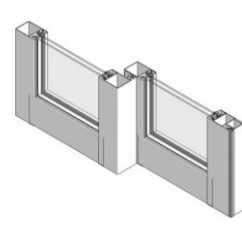

Sliding Windows

CURTAIN WALLS

Can be used in two options:
Covered façade and half covered facade

View: 70mm view from the inner and outer surface

Wall thickness: 3mm - 5mm

System Depth: 210mm

FIXED and SLIDING

Capacity: Sliding systems bear a wing carrying capacity of max 300 kg

Wall thickness: 2mm

System Depth: 118mm

DOORS

Wall thickness: 2mm

System Depth: 90mm

Why **BULLETSHIELD** System



Modular System

System is adjustable and portable



Reusability

Frames can be reused up to 90% post attack



Comprehensive Performance

Provides sound and heat insulation, through its 3 gasket barrier system



Unlimited Colours

Frames can be coated with any choice of RAL color



Unbeatable Flexibility In Design

A single system can be used for all glass classes (BR2 / BR3 / BR4 / BR5 / BR6), thanks to its glazing beads

BULLETSHIELD Testing

EN 1063 and EN 1523 specifies that the main requirement for bullet-resistant glazing is to prevent the passage of projectiles from various types of weapon. The classification of bullet-resistance of glazing in this standard is a technical classification, based on common weapons and ammunition, in order of attacking power.

Weapon of ammunition is chosen corresponding to the level of bullet resistance being tested. Testing to EN standards requires the test panel to be shot three times at a striking distance of 120 (+/- 1) mm. The panel is considered to fulfill the ballistic classification if there is no perforation of the glazing by the bullet or parts of the bullet. In case of NS (non-splinter) classification there should be no perforation of the witness foil by glass splinters from the rear face.

Security during
the event of
a bullet attack

Bullet attack tested with
.357 Magnum rifle







BURGLARSHIELD

For complete safety against burglar attacks

Residential and commercial burglaries are common these days. The most critical step in a burglary is entry and the common sources of entry includes a window that serves as a means of unlocking an entrance door. To over come such threats Burglar resistant glass and systems are implemented.

Future Glass offers a range of **BURGLARSHIELD** glazing types intended for delayed physical assault and robbery obstruction. **BURGLARSHIELD** units are designed based on estimated time of arrival of security forces. Solid and tough interlayers are configured to hold-off infiltration assaults from mallets, saws, and bars. In case of a constrained assault, the glass and interlayer holds strong for a long time, allowing for remedial action.

BURGLARSHIELD products combine the abrasion resistance of glass with the impact resistance of polycarbonate. They can also be manufactured as laminated polycarbonates for extensive physical attack combined with ballistic performance.

Used for bank teller counters, prisons, villas,
embassies and consulates



Manual attack resistant glasses are classified in different resistance classes depending on their properties. The standard EN 1627 describes the necessary requirements for manual attack

resistant windows, doors and shutters and classifies them in six different resistance classes as shown in the table below.

Class (EN 1627)	Burglar	Static Tests (EN 1628)	Dynamic Tests (EN 1629)	Manual Tests (EN 1630) Tool Set	Contact Duration
RC 1	Occasional	300 kg	50 kg 450mm	Simple tools, Physical force	--
RC 2	Occasional	300 kg	50 kg 450mm	Above + Simple tools (Screwdriver, Pliers, Wood/ Plastic wedges, Saws)	3 Min
RC 3	Moderate	600 kg	50 kg 750mm	Above + additional Screwdrivers, Crowbar, Small hammer, Hand drill, Drift pin	5 Min
RC 4	Experienced	1000 kg	--	Above + Heavy hammer, Axe, Wood chisel, Metal chisel, Bolt-cutter, Hand chisel and Portable drill	10 Min
RC 5	Experienced	1500 kg	--	Above + Electric tools (Drill, Portable jigsaw, Sabre saw, Angle grinder)	15 Min
RC 6	Experienced	1500 kg	--	Above + sledgehammer, Steel wedge, Powerful electric tools (Grinder, Impact hammer)	20 Min

The **BURGLARSHIELD** SYSTEM

Future Glazing offers flexible system solutions for windows, doors and facades with burglar resistant requirements. The systems have been designed to meet the overall aesthetics while achieving the functional requirements of the resistance class specified.

This is achieved because the protection mechanisms are integrated predominantly inside the units. Windows and doors with unique security fittings are available to guarantee the well-being of assets and individuals.

System Offerings

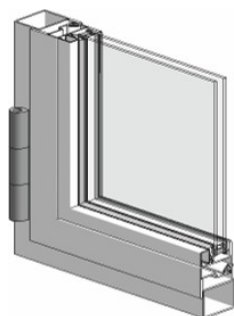

DOORS

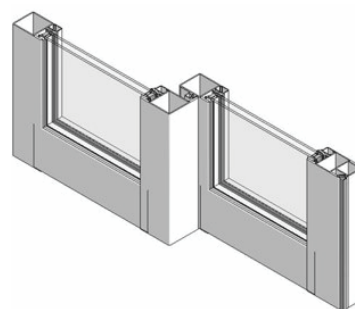

SLIDING WINDOW

Security Level	RC3 according to EN 1627-30	RC3 according to EN 1627-30
Performance	U-Value: 1.70 W/m ² K Air permeability: Class 4 Water tightness: Class 6A Wind pressure resistance: Class C3	U-Value: 1.20 W/m ² K Air permeability: Class 4 Water tightness: Class 7A Wind pressure resistance: Class B3
Weight Carrying Capacity	Max weight per leaf – 150 kg	Max weight per leaf – 300 kg

Why **BURGLARSHIELD** System



Extremely slender visible section width



Diversity in usage



European Hardware and accessories



Individual profile design

BURGLARSHIELD Testing

EN 1627 defines Burglar Resistance as the property of a door, window or shutter, to resist attempts at forced entry into the protected room or area. By applying physical force and with the aid of predefined tools, the window, door or shutter is damaged or destroyed. The criteria for measuring this resistance is defined in EN 1627 standard.

Burglar resistant elements are complete, functioning elements that comply with this standard. These elements when built in and fastened or fastened and locked, have the function of resisting forced entry through the application of physical force assisted by predefined tools.

Glass and other hardware's are picked based on the resistance class required. Testing to EN standard requires the glass and framing system to be attacked physically with different tools for a specific measure of time. It classifies to a specific resistance class of burglary, if it surpasses the required time with characterized tools.

Resistance from
intruder and forced
entry

Attack tested with hand tools
below 1.5m length

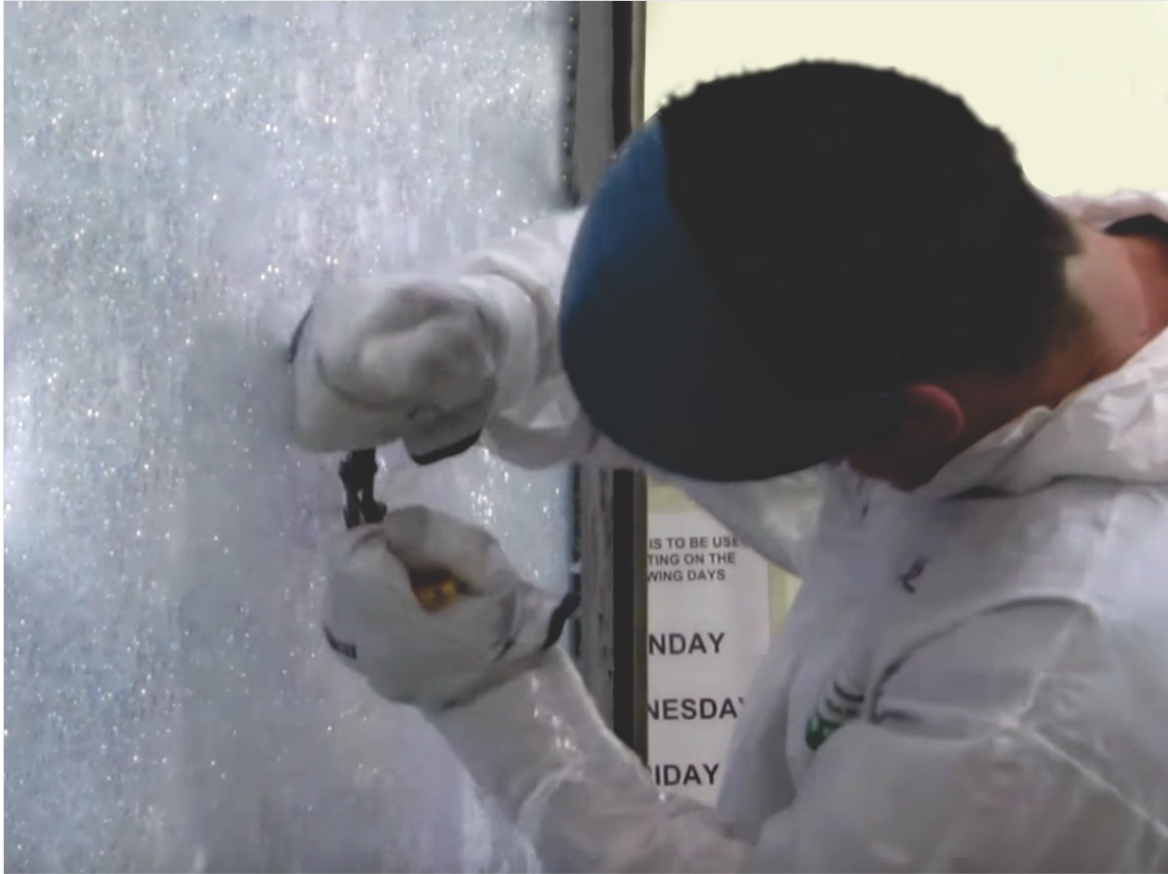

FUTURE | GLASS



BLASTSHIELD

For complete safety against blast attacks

BLASTSHIELD units are blast-resistant glasses specially configured to withstand grenade and bomb attacks. The glass is designed to hold firmly in place in the event of a blast. All **BLASTSHIELD** units can be manufactured using tinted or coated glasses to match the facade or window aesthetic. It is important to note that a blast resistant window operates as a system. It involves not only the glass but also the framing system, the anchoring system and even the structure of the building. A frame that is not designed to withstand a blast or that is not anchored properly may not hold the glazing during a blast situation causing unnecessary failure and possible injury. A qualified blast engineer should be consulted for the design of each project.

Minimum Size	250 mm X 350 mm
Maximum Size	2500 mm X 5000 mm
Thickness Range	8 mm to 30 mm

BLASTSHIELD blast resistant glass typically uses a multiple layered combination of incredibly robust laminated glass and polycarbonates to reduce the risk of flying glass debris in the event of an explosion. The glass can be manufactured using tinted or reflective glasses to match the facade aesthetics.

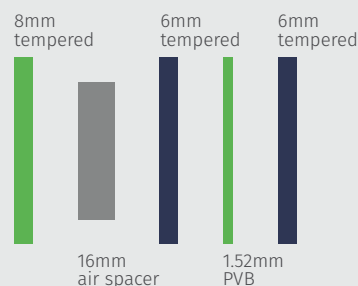

Used for embassies and consulates

The **BLASTSHIELD** Design

The design of a blast window system involves very detailed areas of design. First the peak pressure must be determined from the size of the charge and the set back distance from that charge. Then a positive phase duration must be known to determine the impulse of the blast wave. Finally a performance condition must be specified to determine the expected performance level.

With this information a computer model can be constructed to determine the specific thickness or layers of material needed to contain the blast

within the specified performance criteria. Please see the chart overleaf for performance conditions. (GSA Test Protocol: GSA-TS01-2003 and ISO 16933).

It is important to note that a blast resistant window operates as a system. It involves not only the glass itself, but also the framing system, anchoring system and even the structure of the building. A frame that is not designed for blast or that is not anchored properly may not hold the glazing during a blast situation causing unnecessary failure and possible injury. A qualified blast engineer should be consulted for the design of each project.

Air Blast Test

In accordance with ISO 16933

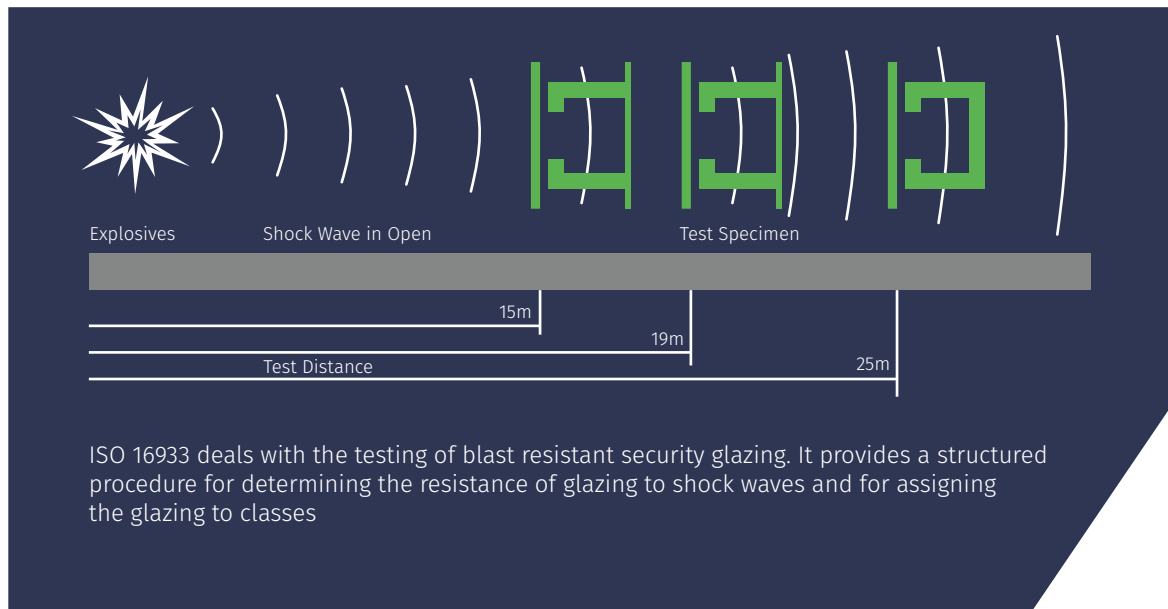

Window Performance Condition and Glass Fragmentation Diagram

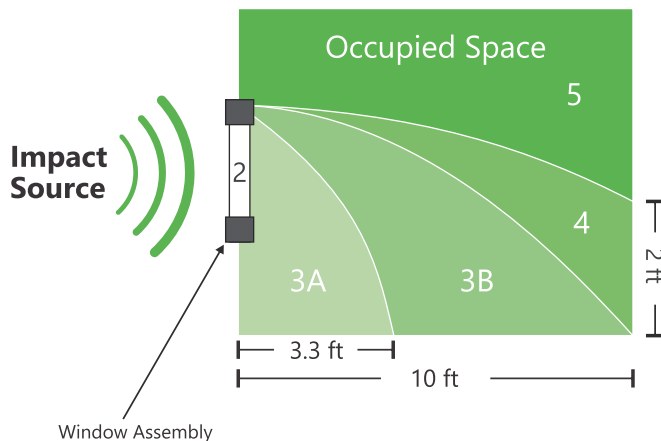

Classification Criteria

In accordance with ISO 16933

Classification	Peak Pressure of the Shock Wave [kPa]	Positive Impulse [kPa-ms]
EXV45(X)	30	180
EXV33(X)	50	250
EXV25(X)	80	380
EXV19(X)	140	600
EXV15(X)	250	850
EXV12(X)	450	1200
EXV10(X)	800	1600

Shock Wave

A shock wave is an area of pressure expanding supersonically outward from an explosive core. It has a leading shock front of compressed gases.

Positive Impulse

This is characterized by a nearly instantaneous rise to a maximum pressure followed by an exponential decay to ambient pressure.

Security Level	Performance Condition	Security Level	Hazard Level	Description of Window Glazing Respose
A	1	Safe	No breakage	Glazing does not break. No visible damage to glazing or frame
B	2	Very High	No risk	Glazing cracks but its retained by the frame. Dusting or very small fragments near sil or on floor acceptable
C	3A	High	Minimal risk	Glazing cracks and fragments enter space and land on floor no further then 3.3 ft from window
D	3B	High	Very low risk	Glazing cracks and fragments enter space and land on floor no further then 10 ft from window
E	4	Medium	Low risk	Glazing cracks and fragments enter space and land on floor and impact a vertical witness panel at a distance of no more than 10 ft. from the window at a height no greater than 2 ft. above the floor
F	5	Low	High risk	Glazing cracks and window system fails catastrophically. Fragments enter space, impacting a vertical witness panel at a distance of no more than 10 ft. from the window at a height greater than 2 ft. above the floor

FUTURE | GLAZING



The **BLASTSHIELD** System

In collaboration with **SCHÜCO**

In collaboration with Schuco, the BlastShield System are emergency blast resistant systems that are subjected to extreme conditions. To satisfy all requirements, the glazing systems must be planned in their overall context at an early stage. When using blast resistant systems the focus of planning should not only be on the defined protection aim but also on areas such as building geometry and attachment methods.

Future Glazing offers flexible system solutions for blast resistant windows, doors and facades. Using latest computer-assisted simulations and calculations we can correlate the test results to individual requirements of the projects. Certified in accordance with ISO 16933, the system allows the highest quality of safety and security requirements to be combined with the aesthetics of modern architecture.

System Offerings

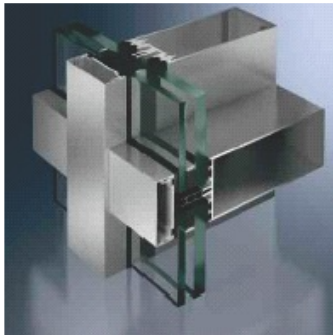

Curtain Walls **FW 80+ XR**

Tested in accordance with ISO 16933 to EXV 15 (D)

.....
Tested unit dimension:

3485mm x 3210mm

.....
Max. tested glass sizes:

1545mm x 1980mm

.....
Thermal insulation:

1.2 W/m²k

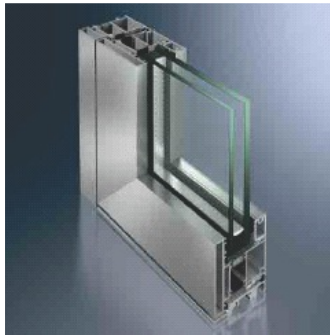

Doors **ADS 90 XR**

Single and double leaf doors (outward opening) tested to EXV 19 (E) in accordance with ISO 16933

.....
Tested vent Size:

1100 x 2250mm

.....
Panic function in accordance with EN 179/EN 1125

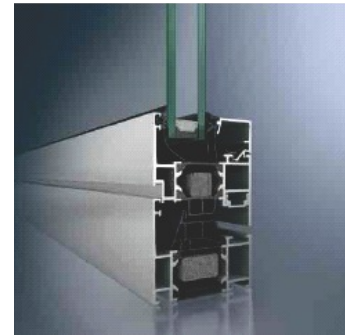

Windows **AWS 90 XR**

Tested to EXV 19 (E) in accordance with ISO 16933

.....
Tested vent size:

1210 x 1840mm

.....
Thermal insulation:

1.6 W/m²k

.....
Provides sound and heat insulation thanks to its EPDM 3 seal design

.....
Different test positions of the window vent (tilted/ turn position/ closed)

Why **BLASTSHIELD** System



Flexibility in Design

Attractive system design and colour that meets today's aesthetic requirements



International Test Compliance

Duly tested accordance with ISO 16933 and compliant to US-GSA standards



Comprehensive Product Range

Wide range of system solutions for blast resistant windows, doors and facades

BLASTSHIELD Testing

In this sensitive market segment, FUTURE GLASS offers perfectly tailored systems in the form of its blast-resistant systems for the optimum level of security. The window, door and façade systems, tested in accordance with ISO 16933, provide protection against explosions. At the same time, they have an attractive appearance and are highly functional.

ISO 16933 deals with the testing of blast resistant security glazing. It provides a structured procedure for determining the resistance of glazing to shock waves and for assigning the glazing to classes.

Pressure and distance of blast is determined with the help of required Hazard rating. The hazard rating that glazing or glazing systems receive is based upon the severity of fragments generated during an air-blast test. The fragment severity is determined based upon the number, size, effects and location of fragments that lie at, or behind, the original location observed during post-test data gathering.

Classification and ratings are assigned based on the performance of glazing loaded by air-blast pressures and impulses, and are specific to the blast characteristics under which the test takes place. Glazing that has received an air-blast classification and rating is suitable for use only if installed in a properly designed frame.

Reliable protection
in the event of
an explosion

1: The controlled explosion

2: Progress of the blast wave showing the
façade deflecting

2: Progress of the same blast wave showing its
impact on windows and doors



Who We Are

Future Architectural Glass, LLC (Future Glass) is a joint venture between a multinational and diversified Singapore corporation and a leading Indian glass conglomerate. The company has established itself as UAE's premium glass processor having the entire gamut of European machinery and systems to process any type of interior and exterior glass.

Since 1976, the group has been serving the needs of architectural glass market by providing latest products suiting the dynamic needs of architects/consultant. We started operations as a glass trading and distribution firm and ever since have expanded our products and services to include safety glass manufacturing and providing specialty glass solutions.

In the last four decades, we have diversified into several products lines encompassing exciting exteriors glazing products, comfortable interior

glazing, specialty design applications and high performance green building product solutions.

Our specialized products development unit, is dedicated to understand the changing needs of the architectural glass market and introduce innovative glass and glazing solutions for enhanced comfort, safety and performance. Spread over more than 30 countries worldwide, our strong client base is an indicator of our global reach and the trust we share with our customers.

Our ever-expanding presence with offices in UAE, India and Singapore helps us serve the varied needs of client promptly and efficiently. With multiple manufacturing bases in UAE and India, we are able to optimize resources and utilize the location advantage to the benefits of our global clientele.



Key Indicators



5

Million panels delivered worldwide

2

Manufacturing base – UAE and India

3

Regional headquarters – UAE, India, Singapore

4+

Decades Group's experience in Glass

35+

Countries exports worldwide

1000

Employees group strength

500,000

Sq.ft. area of Factory space

FUTURE

Tomorrow starts today



FUTURE

OFFICE

2411 Churchill Tower, Business Bay, PO Box 117259, Dubai

☎ +971 4 346 1279 | ✉ sales@faglass.com

WORKS

P278 Al Ghail Industrial Area, Ras Al Khaimah (UAE), PO Box 86001

☎ +971 7 258 9274 | 📠 +971 7 258 9071

www.faglass.com



  /faglass